

Tubelok Tie Chord Assembly User Guide

© Level Concept Products Limited

www.lcp-limited.co.uk

01582 882021

Westhey manor barns, Higham road, Barton-le-clay, Bedfordshire, MK45 4RB

About this guide

Contents

- About this guide
 - Contents
 - Revisions
 - Scope and purpose
- Safety
- Components
- Step-by-Step construction
 - Starting out
 - Non-Adjustable side
 - Adjustable side
 - Adding Bracing

Revisions

Issue	Date	Summary of changes
Original issue	10/10/2022	-

Scope and purpose

LCP's Tie Bar solution is compatible with the majority of Temporary Roof systems. The end plate is the only component required specific to each system. It has a unique in built end connector which allows the user to post tension the truss. The roof system used in this guide is for illustration purposes only.

Safety

Assembly, alteration and dismantling of the overall structure involve the potential risk of falls. Perform the assembly work in such a way that the risk of falls is avoided as far as possible and that the residual risk is minimised. Please refer to the roof manufacturers guidelines on safety.

In relation to the installation of the tie bar it is important each section is locked and secured in position to prevent rotation. To complete the installation, the locking nuts must be securely tightened with an adjustable spanner.

Components

Item code	Description	Illustration
IDTL0500 IDTL1000 IDTL1250 IDTL1500 IDTL1750 IDTL2000 IDTL2500 IDTL3000 IDTL4000 IDTL5000	iDent Tubelok	
TBEP06	EV 6 Hole Tension Bar End Plate Assembly	
TBEP08	EX 8 Hole Tension Bar End Plate Assembly	
TBME01	Male Tubelok End Connector c/w M20 Bolt Assembly	

TBFE01	Female Tubelok End Connector	
TBB030	30mm Bullet	
TBLP030	Lynch Pin	
EVQR1260	Quick Release Pins M12x60	
M12x90	M12 Bolt x90 Nut Washer	

Starting Out

Insert appropriate Spigots into Lattice Beam
And secure with correct number of quick release
pins (QR1260) on the top chord. Bottom chord to
be secured with M12x90 Bolts.

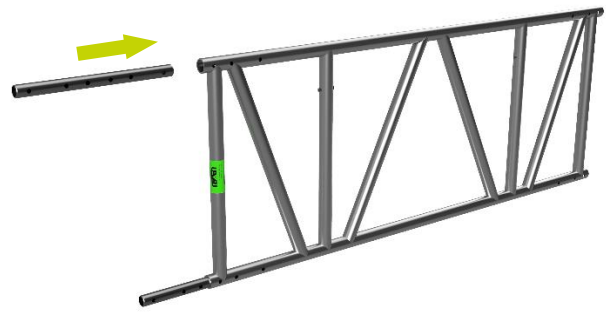
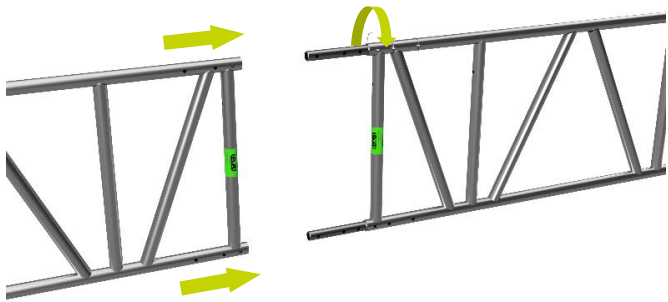

Insert and secure Pins as shown for top joint
Connect next lattice beam



Safety: Ensure
Quick Release Pins
are orientated
upwards as shown

Align Tension Bar End Plate Assembly as shown
Insert M12 Bolt c/w a Washer and Nut.

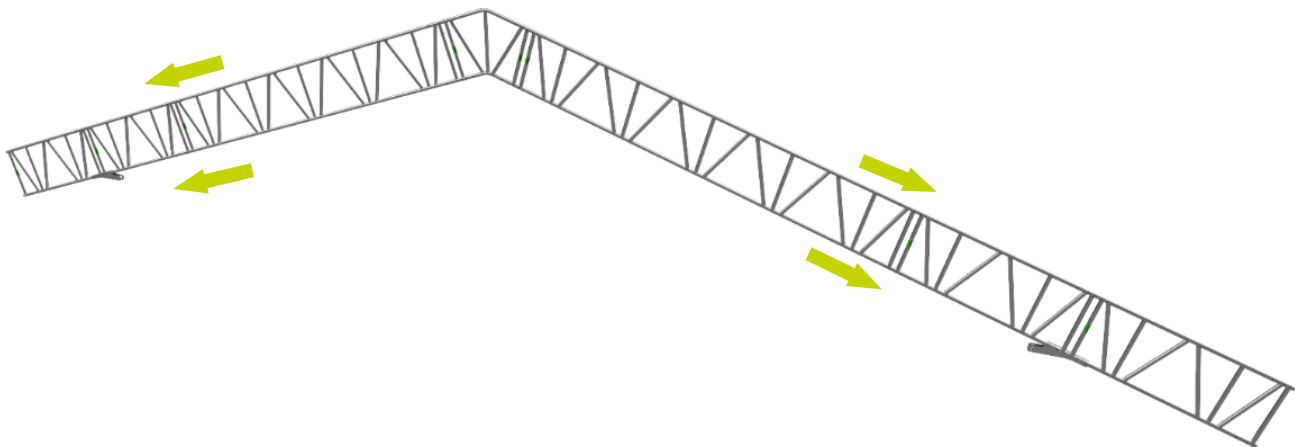
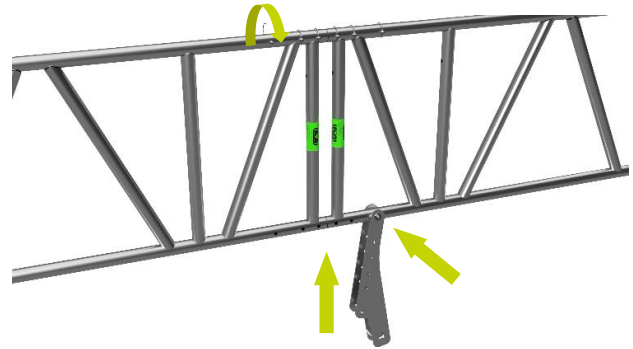

Rotate Tension Bar End Plate Assembly insert the remaining of the M12 Bolts Washers and Nuts.
Continue connecting Lattice beams to achieve the span required.

Fixed end

Insert Female Coupler into the tension bar end plate assembly
Secure with 30mm Bullet and Lynch Pin

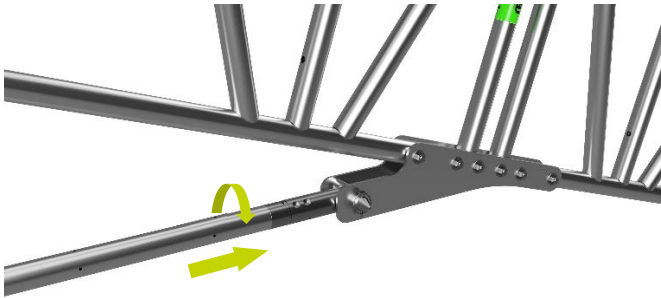
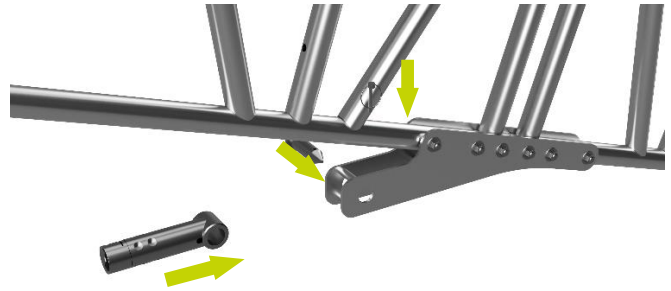

Connect first length of TubeLok and rotate to lock in position and align coupler mark.



Safety: Ensure TubeLok indicator is between min and max

Add the first Dropper adjacent to a node-point along Lattice Beam using a Right Angled and Swivel Couplers

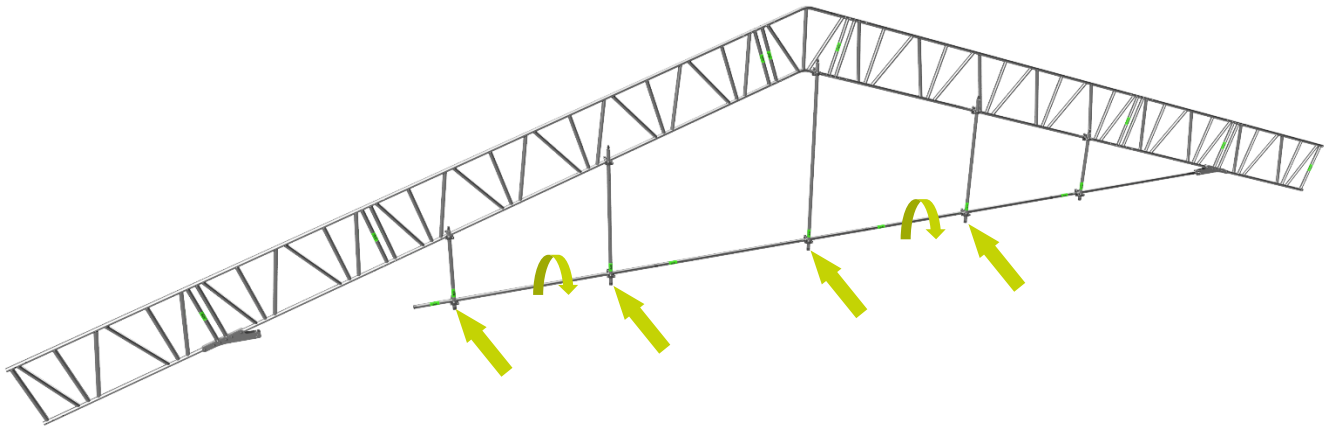
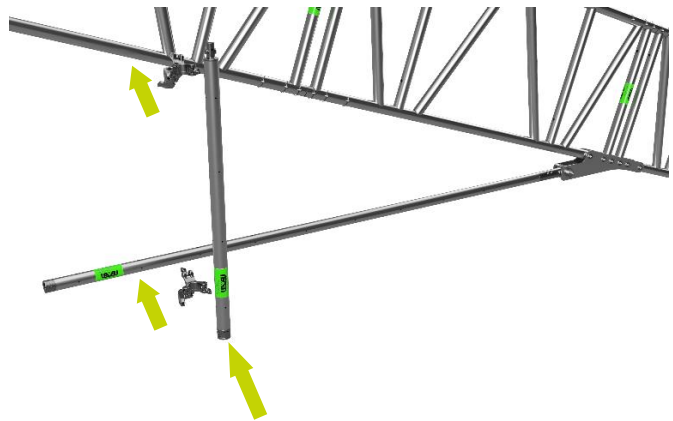

Continue as detailed adding further lengths of tubelok as required.
Droppers to be added progressively to keep tube locked at maximum 3.0m c/c or as specified by designer.

Adjustable end

Select appropriate length Male End Connector c/w M20 Bolt Assembly and adjust length to suit desired span

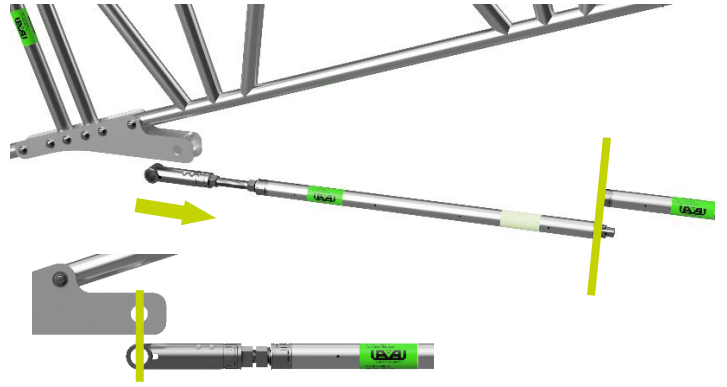
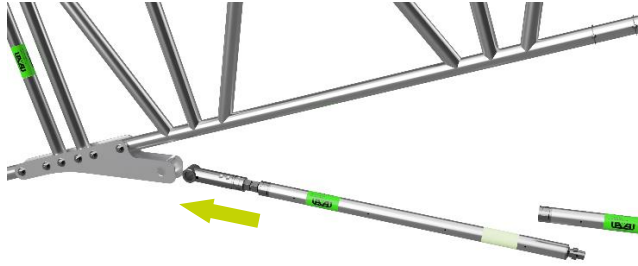

Slide Assembly between the pins of the Tension Bar End Plate Assembly past the 32mm hole

Slide back and connect to the adjacent TubeLok
Rotate and lock

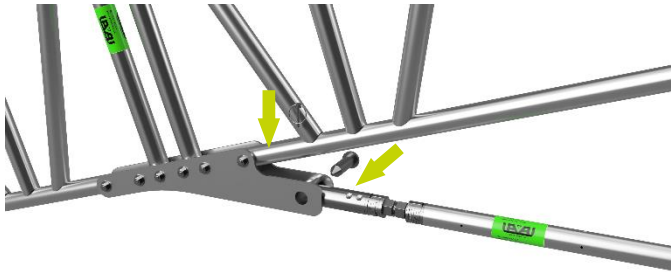
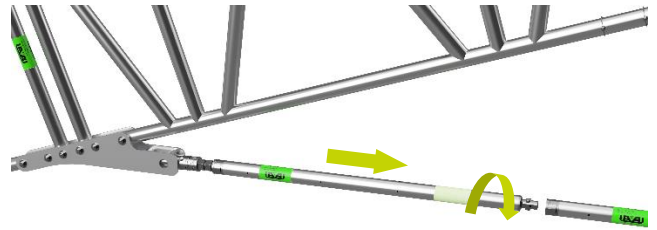

Insert 30mm Bullet
And secure with Lynch Pin

The Truss can be post tensioned using the
adjustment assembly as shown
To be advised by Engineer

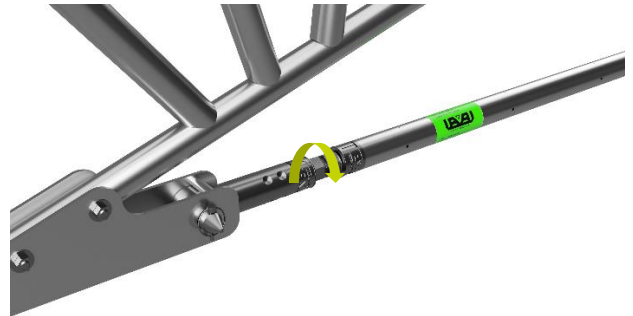

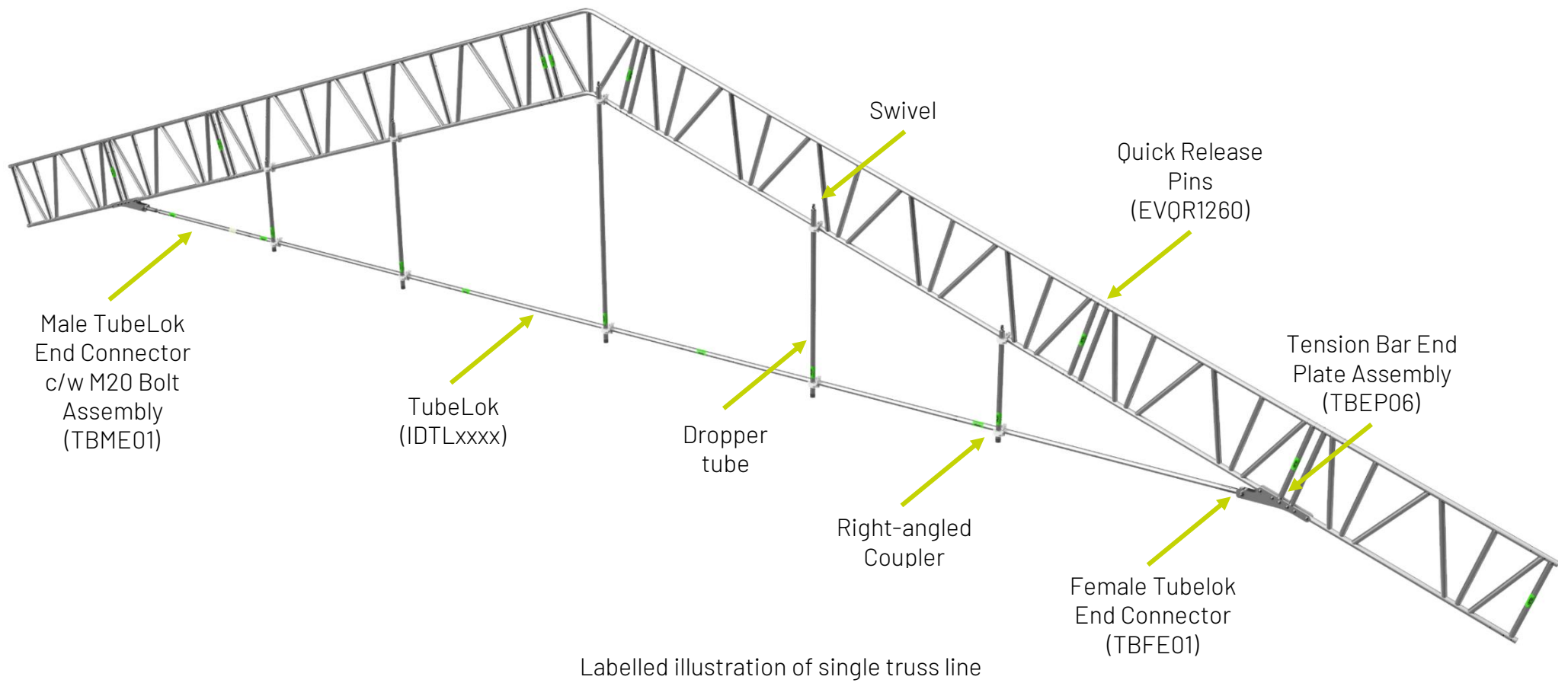

Adding Bracing

Construct roof section as per manufactures guidelines whether by hand, crane or roll out.
Image below for illustration purposes only, components coloured for clarity.
Additional bracing may be required, to be determined by design engineer.

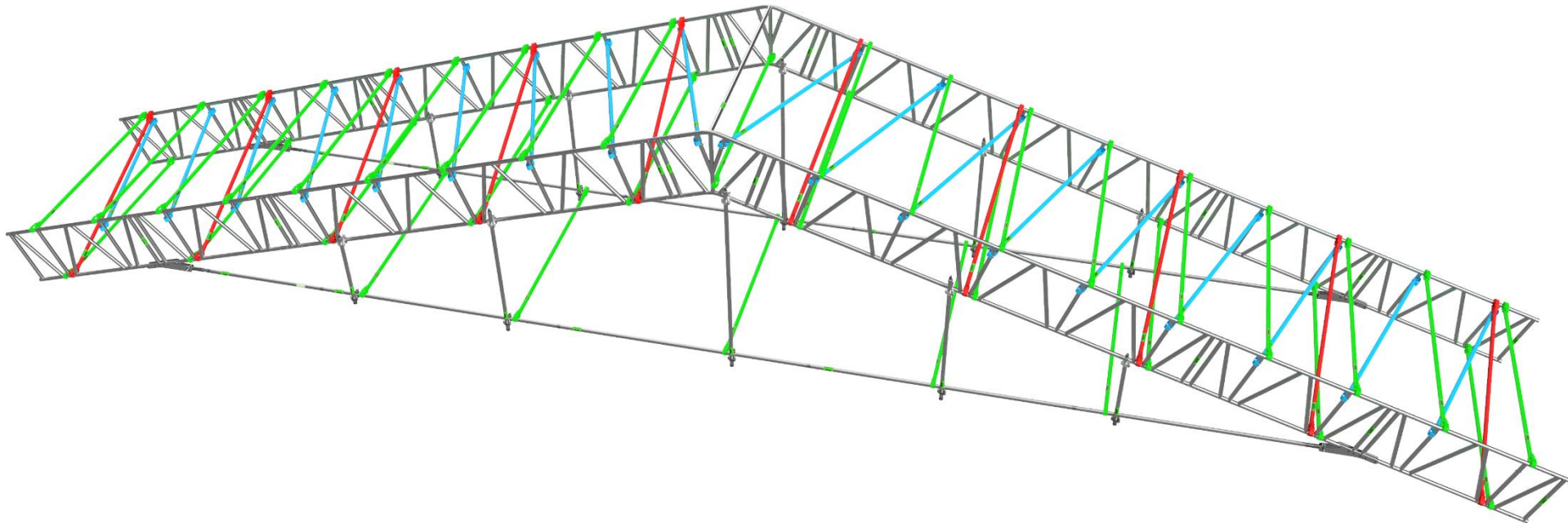

Green Horizontal Brace
Red Section Brace
Blue Plan Brace